



BPS-2020 / Bypass Switcher



System Overview and Operations

BPS-2020/Bypass Switcher Operations Guide

- Document Number:82102-0022
- Document Version: 2.0.1
- Date: February 23, 2012
- Printed in U.S.A.

Copyrights and Trademarks

© 2012 Utah Scientific, Inc., All rights reserved. Any use or reproduction of this guide's contents without the prior written consent of Utah Scientific, Inc. is strictly prohibited.

- BPS-2020 is a trademark of Utah Scientific, Inc.
- Windows references (all versions) are registered trademarks of Microsoft Corporation.
- All other product names and any registered or unregistered trademarks mentioned in this guide are used for identification purposes only and remain the exclusive property of their respective owners.

Notice

Information contained in this guide is subject to change without notice or obligation. While every effort has been made to ensure that the information is accurate as of the publication date, Utah Scientific, Inc. assumes no liability for errors or omissions. In addition, Utah Scientific, Inc. assumes no responsibility for damages resulting from the use of this guide.

FCC Compliance (USA) and Digital Equipment Compliance (Canada)

This equipment has been tested and found to comply with the limits for a Class A, digital device, pursuant to Part 15, Subpart B of the FCC Rules and the Canadian EMC Requirement (ICES-003). These limits are designed to provide reasonable protection against harmful interference when the equipment is operated in a commercial environment. This equipment generates, uses, and can radiate radio frequency energy and, if not installed and used in accordance with the instruction manual, may cause harmful interference to radio communications. Operation of this equipment in a residential area is likely to cause harmful interference, in which case, the user will be required to correct the interference at their own expense. Shielded cables must be used to ensure compliance with the FCC Class A limits.

Declaration of Conformity

Utah Scientific, Inc.

4750 Wiley Post Way, Suite 150
Salt Lake City, Utah 84116-2878 U.S.A.

We declare our sole responsibility that the Utah-400 Digital Routing Switcher is in conformance with the following standards:

Emission

- EN55022:1994+A1&A2

Immunity

- EN55024:1998
- EN61000-3-2
- EN61000-3-3

Safety

- IEC 60950-1:2001 /EN 60950-1:2001

Following the provisions of the Directive(s) of the Council of the European Union:

- EMC Directive 89/336/EED
- Low Voltage Electrical Directive 72/23/EEC

Utah Scientific, Inc. hereby declares that the product specified above conforms to the above Directive(s) and Standard(s).



Important Safeguards and Notices

This section provides important safety guidelines for the Operator and Service Personnel. Specific warnings and cautions are found throughout the guide where they apply, but may not appear here. Please read and follow the important safety information, specifically those instructions related to risk of fire, electric shock, or injury to persons.

Safety Symbols



- Hazardous Voltage symbol



- Caution symbol. The product is marked with this symbol when it is necessary to refer to the manual to prevent damage to the product.

Warnings

Please observe the following important warnings:



- Any instructions in this guide that require opening the chassis, changing a power supply, or removing a board, should be performed by qualified personnel only. To reduce the risk of electric shock, do not perform any service unless you are qualified to do so.
- Heed all warnings on the unit and in the operating instructions.
- Do not use this product in or near water. Disconnect AC power before installing any options or servicing the unit unless instructed to do so by this manual.
- This product is grounded through the power cord ground conductor. To avoid electric shock, plug the power cord into a properly wired receptacle before connecting the product inputs or outputs.
- Route power cords and other cables so they won't be damaged.
- The AC receptacle (socket) should be located near the equipment and be easily accessible.
- Disconnect power before cleaning. Do not use any liquid or aerosol cleaner - use only a damp cloth.



- Dangerous voltages exist at several points in this product. To avoid personal injury, do not touch exposed conductors and components while power is on. Do not insert anything into either of the systems two-power supply cavities with power connected.
- Do not wear hand jewelry or watches when troubleshooting high current circuits, such as power supplies. During installation, do not use the door handles or front panels to lift the equipment as they may open abruptly and injure you.
- To avoid fire hazard when replacing fuses, use only the specified correct type, voltage and current rating as referenced in the appropriate parts list for this product. Always refer fuse replacement to qualified service personnel.
- Have qualified personnel perform safety checks after any service.

Cautions

Please observe the following important cautions:



- When installing this equipment do not install power cords to building surfaces. To prevent damage when replacing fuses, locate and correct the problem that caused the fuse to blow, before reconnecting power.
- Use only specified replacement parts

Notices

Please observe the following important notes:



- When the adjacent symbol is indicated on the chassis, please refer to the manual for additional information.
- For the HD-2020 Chassis and Master Control Panel, refer to “Connecting and Disconnecting Power” - Chapter 2 (Hardware Installation).

Company Information

Utah Scientific, Incorporated

**4750 Wiley Post Way, Suite 150
Salt Lake City, Utah 84116-2878 U.S.A.**

- Telephone: +1 (801) 575-8801
- FAX: +1 (801) 537-3098
- Technical Services (voice): +1 (800) 447-7204
- Technical Services (FAX): +1 (801) 537-3069
- E-Mail -General Information: info@utsci.com
- E-Mail -Technical Services: service@utsci.com
- World Wide Web: <http://www.utahscientific.com>
- **After Hours Emergency:** +1 (800) 447-7204. Follow the menu instructions for Emergency Service.

Warranty Policies

Hardware Warranty

Utah Scientific, Inc. warrants to the original purchaser that the Utah Scientific hardware is free from defects in materials and workmanship and will perform substantially in accordance with the accompanying written materials under normal use and service for a period of ten (10) years from the date of shipment. Any implied warranties on hardware are limited to ten (10) years. Some states/jurisdictions do not allow limitations on duration of an implied warranty, so the above limitation may not apply to certain specific purchasers.

Software Warranty

Utah Scientific warrants that the software will perform substantially in accordance with the accompanying written materials for a period of one (1) year from the date of shipment.

Customer Remedies

For the first one (1) year after purchase of the software and the first ten (10) years after the date of purchase of the hardware, Utah Scientific's and its suppliers' entire liability and purchaser's exclusive remedy shall be, at Utah Scientific's option, either:

- Return of the price paid, or
- Repair or replacement of the software or hardware that does not meet the above warranties and is returned to Utah Scientific under the returned materials authorization (RMA) process with freight and forwarding charges paid.

After the initial warranty periods, purchaser's exclusive remedy is the repair or replacement of the hardware upon payment of a fixed fee to cover handling and service costs based on Utah Scientific's then-current price schedule. The above warranties are void if failure of the software or hardware has resulted from an accident, abuse, or misapplication. Any replacement software or hardware will be warranted for the remainder of the original warranty period or thirty (30) days, whichever is longer.

No other warranties. To the maximum extent permitted by applicable law, Utah Scientific and its suppliers disclaim all other warranties, either express or implied, including, but not limited to implied warranties of merchantability and fitness for a particular purpose, with regard to the software, the accompanying written materials, and any accompanying hardware. This limited warranty gives the purchaser specific legal rights. These rights may vary in certain states/ jurisdictions.

No liability for consequential damages. To the maximum extent permitted by applicable law, in no event shall Utah Scientific or its suppliers be liable for any damages whatsoever (including without limitation, damages for loss of business profits, business interruption, loss of business information, or any other pecuniary loss) arising out of the use of or inability to use Utah Scientific products, even if Utah Scientific has been advised of the possibility of such damages. Because some states/jurisdictions do not allow the exclusion or limitation of liability for consequential or incidental damages, the above limitation may not apply in those circumstances.



BPS-2020 / Bypass Switcher

Table of Contents

1 - BPS-2020 (Bypass Switcher)

Receiving the System - Unpacking	1-1
General Overview	1-2
How the System is Used	1-2
System Layout	1-2
Control Panel Variations	1-2
Video Card Variations	1-3
Audio Card Options	1-3
System Installation	1-4
Rack Mounting	1-4
Control Interconnections	1-4
Multichannel Connections	1-5
Video Connections	1-6
Operation of the BPS-CP-16	1-7
Rear Panel Audio Connections	1-7
Card Installation	1-8
PCB Mounted Controls and Indicators	1-9
Power Supplies	1-9
Crosspoint/Control Card (121188-1, -2)	1-10
Crosspoint/Control Card - continued	1-13
BPS-2020 Video DA Card	1-14
BPS-2020 Video 8x1 Input Card	1-14
BPS-2020 AES Crosspoint	1-14
BPS-2020 Analog Audio Crosspoint	1-14
BPS-2020 Deluxe Audio Crosspoint (121178-1/2)	1-15
BPS-2020 Clean Quiet Module	1-16

2 - Operation

Initial System Power up	2-1
Control Panel Usage	2-2
Indications	2-2
Control Options	2-2
Initial System Configuration	2-3
Other operational Scenarios	2-5

Forcing the bypass relay	2-5
Changing the reference standard	2-5
Rear Panel Description	2-6
Control Connectors	2-6

3 - Specifications

Overview	3-1
Power Supplies	3-4

Appendix A - Rear Panel Pinout Detail

Serial Port	A-1
RS-232 Mode	A-1
RS-422 Mode	A-1
Tally Output	A-2
Audio Connections	A-3
Audio Input/Output Connectors	A-3
Output Connectors Pinout	A-4

Appendix B - BPS-2020 Break Out Addendum

In This Addendum	B-1
Using the UTAH-200 Breakout Panel on the BPS-2020	B-2

Appendix C Debug Port C-1

Description	C-1
Connector	C-1
Terminal Emulation Settings	C-2
Verifying Communication	C-2

Appendix D - Firmware Update Procedure

Description	D-1
Procedure	D-1



1

BPS-2020 (Bypass Switcher)

Receiving the System - Unpacking

The BPS-2020 consists of a 2 rack unit electronics frame and one or more control panels. Power cards are provided for each device.

The 1 rack unit control panel can exist as the following versions; the BPS-8 (eight button control panel), the BPS-16 (multi-channel control panel), or the BPS-16S (16 source control panel). See your sales order for details.

Receiving the System - Unpacking	1-1
General Overview	1-2
System Installation	1-4
Card Installation	1-8
PCB Mounted Controls and Indicators	1-9

General Overview

How the System is Used

The BPS-2020 is intended to be downstream of all processing equipment in a standard TV station environment. The Audio/Video output would directly feed the transmission system of a station. The system can also be used in any other AV switching application.

System Layout

The BPS-2020's electronic components are housed in a 2RU rack mount frame, while the control panel is contained in a remote 1 RU frame. The electronics frame contains redundant power supplies.

The video section contains two slots; one for a crosspoint and another for a video DA card, which provides looping input, or a video input card in 16 input systems.

The audio section contains two slots for 8x2 crosspoint cards. These cards can exist as analog audio, standard digital audio, or deluxe digital audio.

The BPS supports only balanced audio. A UDA-200 must be used to convert to Unbalanced audio if the installation requires it.

Control Panel Variations

Stand Alone – 8 Standard Veetronix switches that represent one of the 8 inputs, or 16 switches for the 16 input systems.

Multichannel – 16 Veetronix switches in two banks of 8, with one bank representing a channel select, and the other bank selecting one of the eight inputs on that particular channel.

The control panel communicates with the electronics frame via RS-485.



Video Card Variations

There are two different video crosspoint cards. This card is the heart of the system from a control standpoint, and orchestrates all system activities. The 121188-2 card is an 8 input crosspoint, while the 121188-1 is a 16 input crosspoint.

The other video cards are the 8 circuit DA (121182-1), which can only be used in conjunction with the 8 input crosspoint card, and the 121186-1 input card, which contains the additional 8 input circuits for the 121188-1 16 input system.

One other optional module, the 121169-1 Clean/Quiet submodule, can be installed on either one of the crosspoint cards. This module provides error-free switching of un-timed sources to provide the cleanest possible video output.

Audio Card Options

There are 3 audio cards available. The analog audio card (121183-1) is a stereo 8x1 device. Up to two can be installed for a dual stereo system. The standard digital audio card (121184-1) is also an 8x1, dual stream device. Two can be installed for a quad stream system.

The Deluxe Digital Audio card (121178-1) provides a V-Fade transition and can be used as either a Quad 8x1 with two cards or as a dual 16x1.

System Installation

Rack Mounting

The 2 Rack Unit electronics frame should be installed near the master control switcher in the main audio/video path of the system. The 1 Rack Unit control panel should be installed in the Master Control room where it is easily accessible to the operator.

Control Interconnections

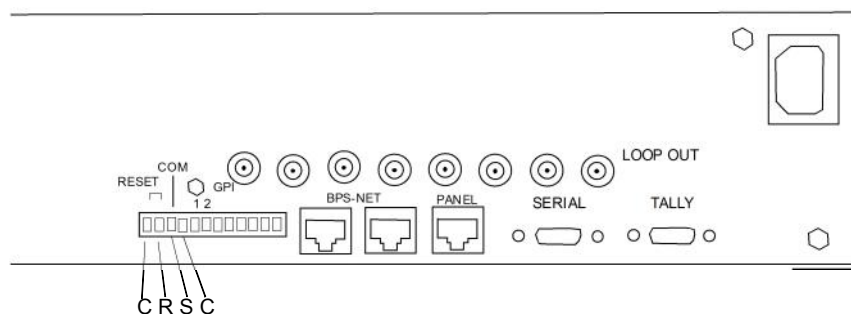

Figure 1-1. Lower right chassis quadrant

This section of the BPS rear panel contains the control interconnections for the system. The necessary connection between the control panel and the electronics frame is a single CAT-5 cable between the panel port and the RJ-45 connector on the back of the panel. Other control connections include RS-232/422, tally and GPI's.

See section 2 for pinout and other details of these control connectors.



Multichannel Connections

Multi-channel BPS-2020 systems can operate as single units, as a networked system, or both. To operate as a multi-channel system, a BPS-CP-16 is required.

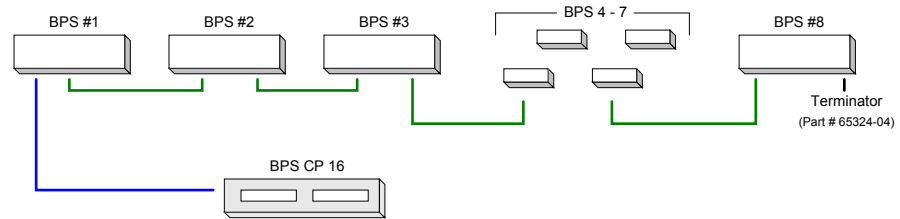

Figure 1-2. Basic Multi-Channel connection

The interconnect between the CP-16 and the bypass switchers is done with standard CAT5 cable. The CP-16 is at one physical end of the bus and is terminated internally. The cable then loops through the BPS-2020 chassis on the two “BPS-NET” RJ-45 connectors. The open connector on the last BPS-2020 should be terminated with USI part number 65324-04.

Note that each BPS-2020 must be addressed with a dipswitch on the video crosspoint card.

Video Connections

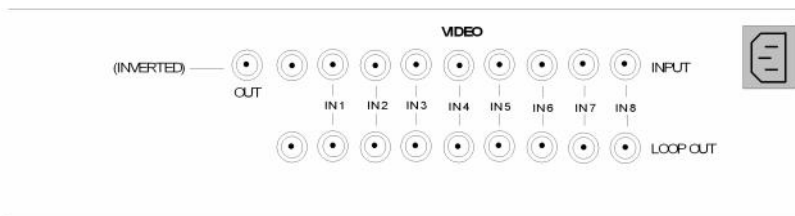

Figure 1-3. 8-Input systems

Standard video ports include 8 inputs and 1 dual output connection. Optionally, a DA card can be purchased that provides an active loop output for each input.

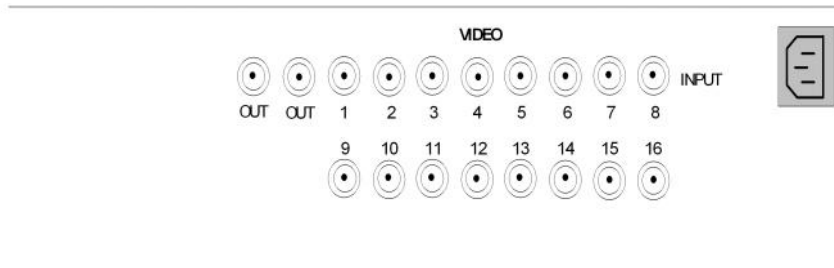

Figure 1-4. 16-Input systems

16-Input systems contain updated legends to describe the different BNC functions. This system requires a 16x1 crosspoint card as well as an 8x input card to be installed in the lower video slot.



Operation of the BPS-CP-16

Operation is very straight forward. The left bank of 8 buttons selects the BPS-2020 chassis you wish to control. When a channel is selected, the right bank of buttons will show its current status. A cycling lamp pattern will indicate that the designated address is not communicating.

Rear Panel Audio Connections

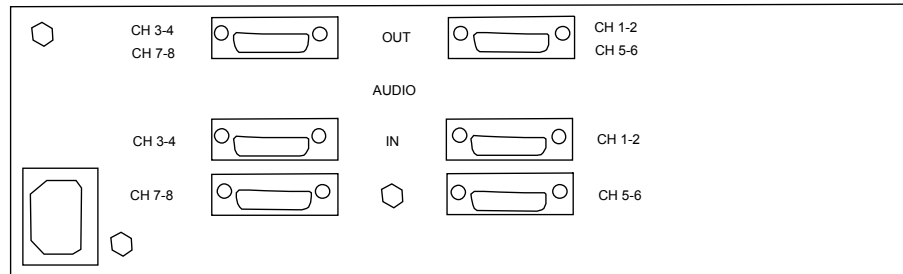

Figure 1-5. Left side of rear panel

Audio connections are contained within the 26 pin high density D connector. The audio can be analog, digital, or not installed depending on what was purchased. See the 'Card Installation' section on page (1-6) to determine which cards are installed in your system. Section 2 contains pinout information for the 'D' connectors.

Card Installation

The BPS -2020 has two power supply slots and four slots for plug-in cards. The following list shows which cards can be placed in which slots

1. Power Supplies – USI PN 140080-02.
2. Slot 1 – Either the 121188-2 8x1 crosspoint or the 121188-1 16x1 crosspoint can be installed in this slot.
3. Slot 2 – Either the 121182-1 video DA or the 121186-1 8x1 input card can be installed here. The 121182-1 should only be used with the 121188-2 8x1 crosspoint, and the 121186-1 should only be used with the 121188-1 16 Input crosspoint.
4. Slots 3, 4 – either the BPS-2020 Digital Audio (121184-1) crosspoint, the BPS-2020 Analog Audio Crosspoint (121183-1), or the Deluxe Audio crosspoint can be placed here.

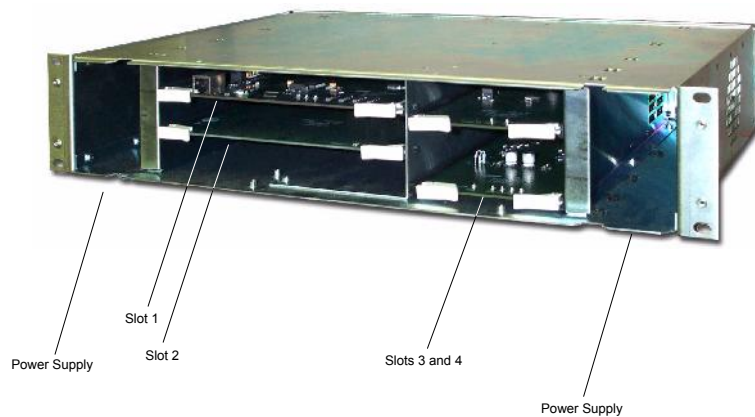

Figure 1-6. Card Installation



PCB Mounted Controls and Indicators

Power Supplies

- The power supplies are calibrated at the factory. No field adjustment is necessary.
- The supplies have Red LED's that indicate failure of the 5V, 3.3V, +-12V, integral fan and overtemperature. They also have a bi-color LED that is green when all other failure leds are off, and red when one or more of the other alarms trip.

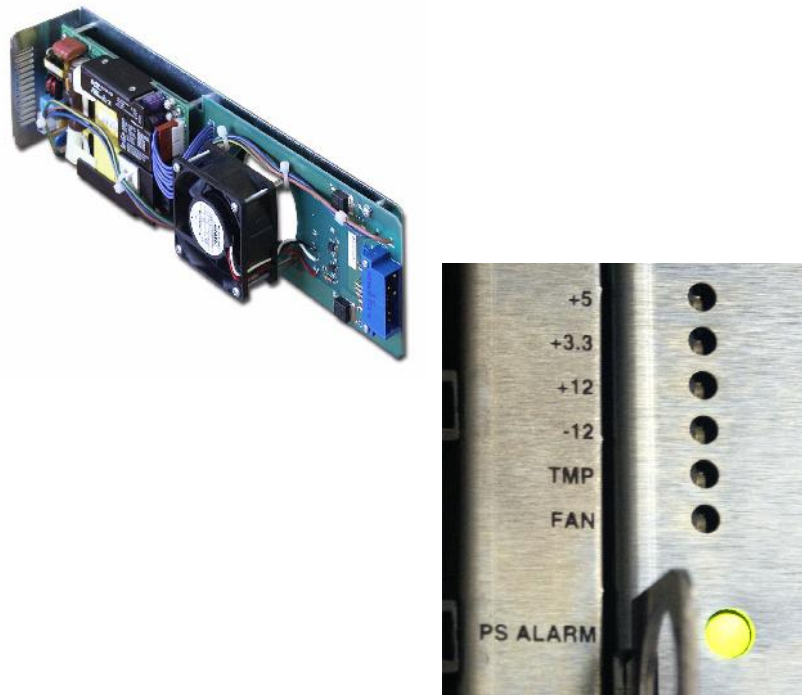

Figure 1-7. Power Supply (card) and front LEDs

Crosspoint/Control Card (121188-1, -2)

BPS-2020 Video Crosspoint/Control Card. This card is the heart of the BPS-2020 system, as it consolidates all control functions as well as the video switching. There are numerous controls on it.

Indicators:

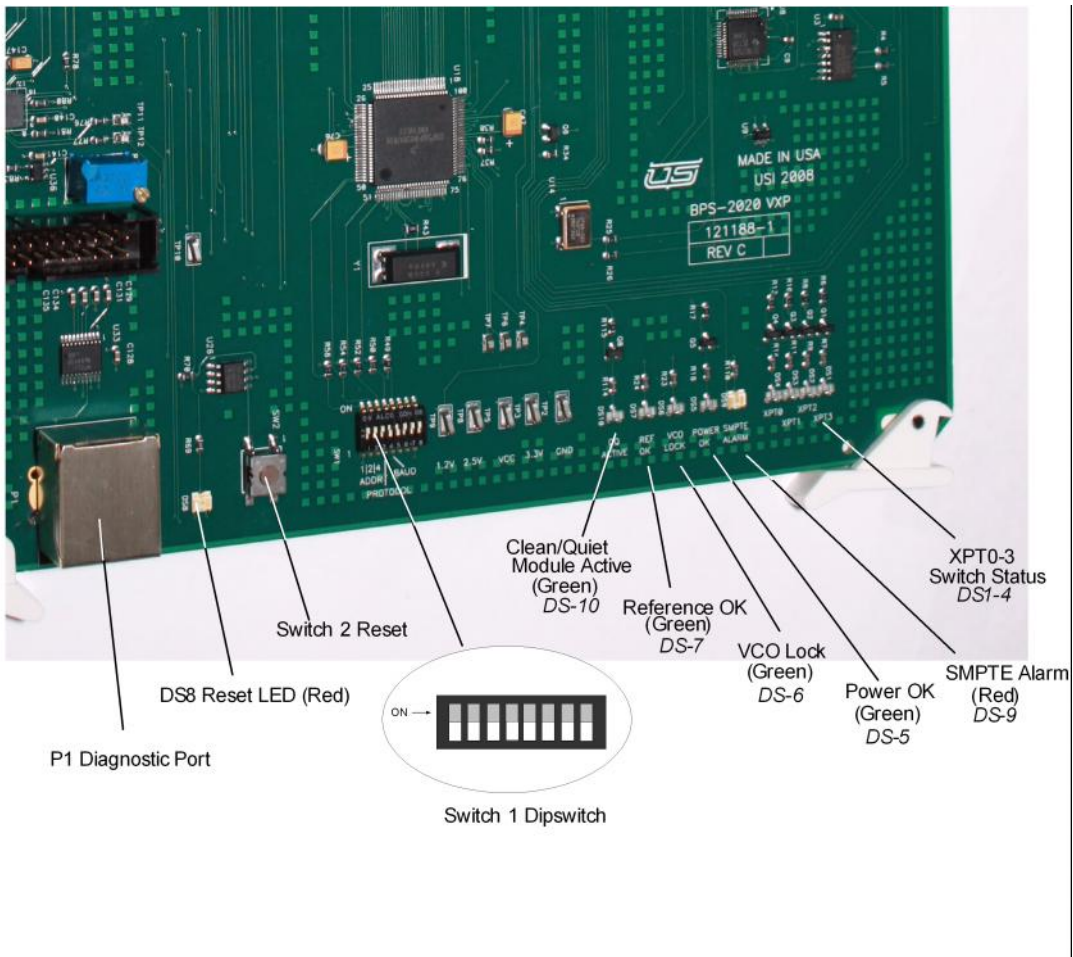

Figure 1-8. Card Indications



- DS Red Reset LED. – This LED being on solid indicates that the board is in reset. No operation will happen when this board is in reset. Hardware failure, power supply failure, or a shorted external RESET input could cause this LED to be on.
- DS9 - SMPTE Alarm
- DS6 - VCO Lock. When on, this indicates the CQ reference circuit is fully locked to the incoming reference circuit.
- DS7 - REF Ok. Indicates that the system reference selection matches the incoming reference video signals (when on).
- DS10 - CQ Active. When on, this indicates that the CQ module is installed and the system is re-aligning video to the reference.
- DS5 Green Power OK LED. When on, this LED indicates that all power supplies are active and within tolerance. A power supply failure is indicated when the LED is off.
- DS1-DS4 Green XPT0-XPT3 LEDs. These LEDs indicate which source is currently active. They are a binary-sided representation of the input, with all off = input 1, all on = input 16.

Controls:

- Dipswitch SW1.
 - ~ Switches 1,2 and 3 form the address of the BPS-2020 when used in a networked environment. All address's must be unique in a networked environment. These switches are unused in a non-networked environment.
 - ~ Switch 4 of SW1 selects the protocol for the serial interface.
 - ON = GVG 10-XL
 - OFF = RCP-1
 - ~ Switch 5 of SW1 sets the baud rate of the serial interface.
 - ON = 19.2KBaud
 - OFF = 38.4Kbaud.
- Both modes use 8, N, 1.*

Important! On BPS-2020 crosspoint cards running software version 2.06C or earlier, the functions of switch 4 and 5 on SW1 are swapped. Switch 4 is for the baud rate, while Switch 5 corresponds to the protocol. Refer to Appendix C to confirm the software version. The version is shown at the top of the menu.

- Jumpers J1 and J2 set the interface type of the serial Port. When set between pins 1 and 2, they set RS-232 mode. Between pins 2-3 selects RS-422. Both jumpers must be moved to correctly set the protocol.



Crosspoint/Control Card - continued

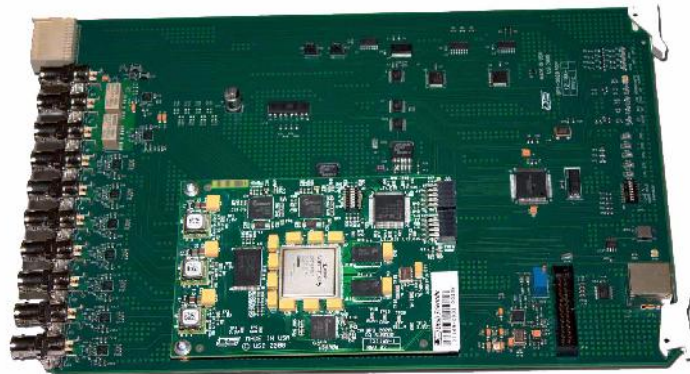

Clean Quiet sub-module

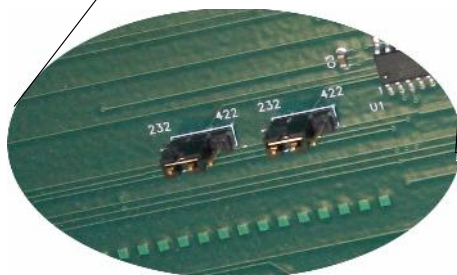

RS 232/422 Jumpers

Figure 1-9. CQ Module and RS 232/422 positions

BPS-2020 Video DA Card

Indicators:

- A green Power OK LED indicates that this card is receiving power correctly.
- Controls – Jumper J19 selects between SD and HD edge rates. Set this according to the type of video you are passing thru the system.

BPS-2020 Video 8x1 Input Card

Indicators:

- Green - Power OK LED
- Controls - None

BPS-2020 AES Crosspoint

Indicators:

- A green Power OK LED indicates that this card is receiving power correctly.

BPS-2020 Analog Audio Crosspoint

Indicators

- Green - Power OK LED



BPS-2020 Deluxe Audio Crosspoint (121178-1/2)



- This module includes the following LED indicators to aid in the evaluating the board and signal conditions.
 - ~ LOOP LCK - Related to the phase lock loop clock system that is implemented on this board. This indicator will appear when the module synchronizes to the reference that is presented.
 - ~ REF OK - When lit, this indicates that a suitable reference is applied to the chassis, and the module has synchronized correctly. This then sends a signal to the input cards indicating synchronization, and that they should accept the reference that is being fed to them as the master clock. (Note: There is a fall back mode in the router if the reference is lost. The system reverts from synchronous operation to asynchronous operation. The router must remain active and continues to pass signals.)
 - ~ S-DET1/2, 3/4 - Indicates signal presence to CH1-2, 3/4.
 - ~ E-DET1/2, 3/4 - Indicates the input signal to CH1-2, 3/4 is synchronized to the reference (DARS).
 - ~ PWR OK - All onboard power supplies are functional (illuminates green).
 - ~ Power Error indications (+5V, 1.2V-2.5V, -5V, 3.3V) - These will illuminate to indicate a problem with a specified power supply. (Note: The illumination of these LEDs will turn off the board power LED.)

- Several test-points are available for board testing purposes. Any field evaluation of these should be done very carefully to avoid damaging the boards.
 - ~ Power test-points (+5V, 2.5V, 1.2V, -5V, 3.3V, GND)
 - ~ VCO – Voltage Controlled Oscillator input level.
 - ~ TAKE – Pulsed high at the time of the input switch.

BPS-2020 Clean Quiet Module

- DS-1 Scangate Active LED. Will flash periodically.
- DS-2 Configuration OK. Indicates the circuitry on this module has properly powered up and is ready for use.





Operation

Initial System Power up

Apply power to the 2RU electronics chassis by connecting power cords to both IEC Inlets. Remove the front cover and verify the following –

- That both power supplies show the large LED Green and no error LED's.
- That all installed cards show the Power OK LEDs as green. (See section 1 for LED locations).

If alarm LED's are present contact USI customer service for assistance.

Interconnect the control panel(s) to the system if not already completed (See section 1 'Control Interconnects' for details). Verify that -

- In the case of a 8 BPS-8 or BPS-16S control panel a single lamp is lit brightly and that pressing other buttons causes that lamp to light.
- In the case of the BPS-NET control panel, select each system with the left hand 'Channel' select buttons, and verify that the right hand 'Source' select buttons show a single lamp lit and change when commanded.

If either control panel shows a pattern of lights that cycle back and forth, it indicates that the panel cannot communicate to the 2RU electronics chassis. Verify that the interconnects are made with standard, straight thru CAT5 or CAT6 cable.

Control Panel Usage

Indications

The control panel contains 8 buttons with integral LED's.

Dim - Backlight

Bright - Currently routed source.

If communication from the panel to the BPS-2020 frame is interrupted, the lamps will cycle back and forth indicating *no communication*.

Control Options

- GPI Based Control. 2 GPI inputs are available (7-8), and when shorted to the available common, cause the BPS-2020 to switch to the corresponding source.
- RS232 / RS422 based control. A serial port is available that allows for control via GVG-10XL protocol or USI RCP-1 protocol depending on the state of an internal dipswitch.
- Remote Control Panels – A standard 8 button remote control panel that can be located up to 1000 feet from the switching electronics frame.

Tally Outputs – 8 TTL indicators that show which of the 8 outputs is active.



Initial System Configuration

No system configuration needs to be performed unless the Clean Quiet module is installed on the video crosspoint card. The Clean Quiet module must be configured to the reference standard and input.

One of the first 8 video inputs must be designated as the reference input for the system. This input must be a standard SMPTE SDI signal that is locked to the same timebase as the other signals in the system, and it must be of the same type as the signals to be routed. This input is fully usable as a source, but should be as stable as possible. A test generator feed such as color bars is recommended. Loss of reference will result in disturbances in the outgoing Audio/Video signal.

Note: Sources labeled 1 - 8 on the rear panel correspond to sources 0 - 7 in the terminal menus.

After this source and the format is determined, you must connect to the debug port (P1) of the video crosspoint card to configure the system. (Appendix C details the connection to this port and the appropriate terminal settings).

Once connected, press the space bar to get the menu screen. The terminal should look like this –

BPS-2020 8/16 System Monitor MENU - V2.00

- 0-7 = Make Switches.
- G = Genlock Part Status.
- Q = Clean Quiet Module Status.
- S = System Level Status.
- W = Write Registers.
- R = CQ Register Dump.
- B = Toggle Bypass Relay.
- C = Configure video standard and reference input.

Press the 'C' key to configure the reference input. When you do, the terminal displays -

Please enter ref standard

0 = 525_60i.
1 = 720_60p.
2 = 1080_29i.
3 = 625_50i.
4 = 720_50p.
5 = 1080_50i.
6 = 720_59p.
7 = 1080_60p.
8 = DISABLE. ->

Press a number key from 0 to 8 depending on the standard you wish to configure. When you do, the terminal will then ask for which input you wish to use-

Please enter source to use for reference (0-7) ->

Press a number key from 0-7 to select that source. After you select the source for the reference, the system will prompt you for the two sources you want activated by the rear panel GPI inputs. Enter a number (0 - 7) for each GPI.

The system then prompts you to enable or disable embedded audio Vfade transitions at the switchpoint. Enter 1 to enable vfade transitions or 0 to disable them.

Once this is complete, the system will immediately go into clean/quiet mode by lighting the CQ Active LED on the video crosspoint card and passing the video thru the clean quiet module. Normal Clean/Quiet operation is indicated by having the CQ active, REF OK and VCO LOCKED LED's on the Video Crosspoint card illuminated.



Other operational Scenarios

Forcing the bypass relay

The system bypass relay connects input 1 to the output BNC closest to it when Bypass mode is active. Bypass is active when the system power is off or a major fault is detected. It can also be enabled from the terminal or the serial port if required for maintenance.

From the debug port –

Press 'B' to toggle the relay on and off.

From the Automation Serial Port –

Using the USI RCP-1 remote control protocol, connect input 000 to output 001 to activate the bypass relay. Connect input 001 to output 001 to return the system to normal operation.

Changing the reference standard

If it becomes necessary to change the reference standard to another input or another standard entirely (from HD to SD for example) the procedure is the same as described above. If changing standards, the system will lose its output signal while acquiring the new reference. Also, if you attempt to pass a signal that does not conform to the new standard the system will put out black/silence that conforms to the new standard.

Rear Panel Description

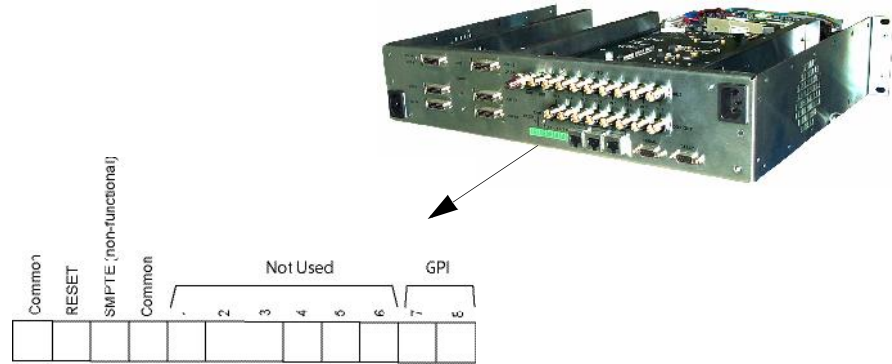

Control Connectors

1. 12 pin terminal block.
 - RESET - The reset pin must receive a high signal in order for the video card to be reset.
 - COM and GPI7-8 pins. Shorting either GPI 7 or 8 pins to the COM pin will cause the router to switch to that input. Multiple shorted pins are ignored. The switch occurs at the time of the connection, no action is performed on the disconnect.
 - BPS-NET ports. These ports are used to interconnect multiple bypass switchers together in a network. Connect a straight-thru CAT5 cable between Bypass Switcher chassis, and at the open connectors on the end of the bus, place USI terminator PN 65324-04.
 - PANEL Port. This port connects to the standard remote control panel in a standalone system, and may connect to nothing in a networked system. The cable is a standard straight thru CAT5 cable terminated in RJ-45 connectors. Length should not exceed 1000 feet.



- Serial Port. This is a switchable 9 pin female D-SUB port used for remote control from PC or automation systems.
 - ~ Format – RS-232 or RS-422 switchable on controller card.
 - ~ Baud Rate – 19.2K or 38.4 K baud, switchable on controller board.
 - ~ Protocol – GVG 10XL or USI RCP-1, switchable on controller board.
- Tally Output.
 - ~ This 9 Pin D-SUB connector is used for connection to a tally system to show which input of the BPS is active. The signal polarity is low = off, high = on. Lows are <.5V and highs are > 3V.
- 2. Audio Connections. 6 High Density 26 pin D-SUB connectors make up the audio connections. These connectors can be wired to directly, or customers can purchase breakout panels. There is a discrete 26 pin connector for each set of inputs, four total. There are 2 Output connectors, with each one supporting the single output for each of the two streams.
- Breakout Options-
 - Unbalanced AES – 1 ea 80318-1 UDA-200 for dual channel AES Systems, 2 ea for Quad channel systems.
 - Balanced AES or Analog Breakout – 1 ea 80317-1 UT200 Balanced BO ASSY for dual channel AES or stereo applications, 2 ea for quad channel AES or dual stereo Analog applications.

3. Video.

- All video connections are BNC.
 - Inputs – 8 BNC's supporting SMPTE259 or SMPTE 292 signals. (16 Inputs optional)
 - Active Loop thru inputs – If ordered, an optional DA card provides a buffered representation of the inputs at the 8 'LOOP OUT' BNC's.
 - Outputs.
 - ~ Two output BNC's are present. They are the normal and complement output of the currently routed source.



3

Specifications

Overview

1. Mechanical
 - 2RU electronics frame.
2. Power Requirement
 - Redundant power supplies with separate power cords.
 - 100-234 VAC input at .5 Amps
3. Video
 - Routes SMPTE 259, 292 or non-standard sources from 1.5Mb/Sec to 1.485 Gb/Sec. All pertinent SMPTE specs are met.
 - Inputs contain cable equalization. Outputs are reclocked.
 - Return loss is less than -15dB at HD rates.
 - Vertical interval switching is performed on the signal format and position of the current output.
 - All inputs can be active loop thru with the purchase of an optional 'DA' card.
4. Analog Audio.
 - Balanced interface
 - 20Hz-20KHZ.

Specifications

- + - .1db gain.
 - +26 dBu max level.
 - -60 dB CMRR at 60 hz.
 - .01% THD.
5. AES Audio.
- Balanced
 - Unreclocked, non-synchronous switch.
 - Switch timing coincident with video switch timing.
 - Supports any AES data rate.
- a. Digital Audio Specifications

Parameter	Specification
Digital Audio Processing	48 kHz. 16 - 24 Bit, AES / EBU; AES-3
Input Impedance - Balanced	110 $\frac{3}{4}$ \pm 20%. 100 KHz. to 6.144 MHz
Input Level minimum	200 mVPP. w/> 50% Eye Pattern Opening
Modes of Operation	Synchronous and Asynchronous
Input Level maximum	7 VPP
Common Mode Range	\pm 7V (DC + Peak Signal)
Common Mode Rejection	Per AES-3, Section 6.3.5 (1997)
Output Impedance - Balanced	110 $\frac{3}{4}$ \pm 20%, 100 kHz. to 6.144 MHz
Output Amplitude	2.0 VPP into 110 $\frac{3}{4}$, minimum
Nominal Rise / Fall Times	25 nano seconds



Common Mode Rejection	>30 dB, DC to 6 MHz
Sample Rate	48 kHz
Intrinsic Jitter	< 0.025 UI Peak, w/700 Hz. HPF Applies to -discrete AES outputs.
Output Phasing with respect to DARS	$\pm 2.5\%$ ($\pm 9^\circ$) of Frame Interval. Applies to -discrete AES outputs.

6. Control.

- Panel to frame.
 - ~ RS-485
 - ~ Status of panel is sent by electronics frame.
 - ~ The connection is via RJ-45.
- Single channel.
 - ~ One button press causes the indicated input to be sent to the output.
- Multichannel
 - ~ In a multichannel environment, the functionality allows the panel to control one of 8 possible electronics frames.
 - ~ Each electronics frame is configured with a Channel number or station number.
 - ~ A user selecting a channel button on the Control Panel that is not directed at the frame it is attached to will cause the panel to attempt to communicate with that other frame, and if successful, allow control of that frame.
 - ~ The physical link between chassis is via RS-485. Connection is via RJ-45.

Specifications

- An RS-232 Serial Port is included, which allows for control from any device communicating in GVG 10X protocol. Connection is via DB9.
- 2 GPI Inputs are available for control. These are Opto Isolated 5-12 V inputs. Connection is via 12 pin barrier strip.
- 8 Tally Outputs are available. These are TTL high true indications that a particular source is selected. Connection is via DB9.

Power Supplies

- Standard Dual Redundant Hot-Swappable power supplies.



A

Rear Panel Pinout Detail

Serial Port

This is a switchable 9 pin female D-SUB port used for remote control from PC or automation systems.

RS-232 Mode

- Pin 2 = Transmit Data Out
- Pin 3 = Receive Data In
- Pin 8 = Ready To Send Out
- Pin 7 = Clear To Send In
- Pin 5 = Ground

RS-422 Mode

- Pin 2 = Transmit Data Out -
- Pin 7 = Transmit Data Out +
- Pin 3 = Receive Data In +
- Pin 8 = Receive Data In -
- Pin 5 = Ground

Tally Output

This 9 Pin D-SUB connector is used for connection to a tally system to show which input of the BPS is active. The signal polarity is low = off, high = on. Lows are $<.5V$ and highs are $> 3V$.

- Tally Connector Pinout
 - Pin 1 – Input 1 tally.
 - Pin 2 – Input 2 tally.
 - Pin 3 – Input 3 tally.
 - Pin 4 – Input 4 tally.
 - Pin 5 – Input 5 tally.
 - Pin 6 – Input 6 tally.
 - Pin 7 – Input 7 tally.
 - Pin 8 – Input 8 tally.
 - Pin 9 – Ground.



Audio Connections

6 High Density 26 pin D-SUB connectors make up the audio connections. These connectors can be wired to directly, or as an alternate, breakout panels can be purchased. There is a discrete 26 pin connector for each set of inputs -- four total. There are 2 Output connectors, with each one supporting the single output for each of the two streams.

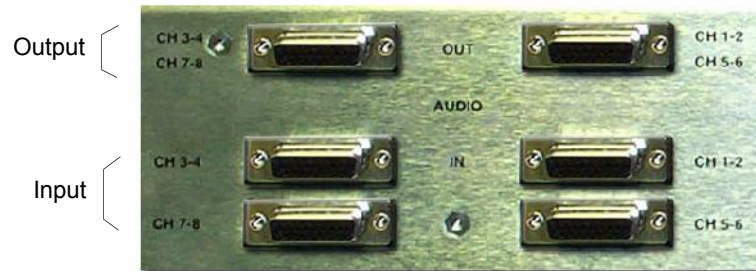

Audio Input/Output Connectors

Input Connectors Pinout (Note: Inputs 1-8 become 9-16 on the bottom board and connectors if configured as a BPS-2020-16)

- Pins 9, 10, 19-26 - Ground.
- Pin 1,11 Input 1 +,-
- Pin 2,12 Input 2 +,-
- Pin 3,13 Input 3 +,-
- Pin 4,14 Input 4 +,-
- Pin 5,15 Input 5 +,-
- Pin 6,16 Input 6 +,-
- Pin 7,17 Input 7 +,-
- Pin 8,18 Input 8 +,-

Output Connectors Pinout

- Pins 3-9, 10, 13-18, 19-26 - Ground.
- Pin 1,11 Output +,- for CH1-2 or 3-4.
- Pin 2,12 Output +,- for CH5-6 or 7-8.
- *Pin 8,18 DARS +,- for System AES Sync.

(*Note: CH 1-2 connector only. Required for Deluxe Crosspoint.)



B

Appendix B

BPS-2020 Break Out Addendum

In This Addendum

This addendum provides important information about using the UT-200 style breakout panel on the BPS-2020 system.

Reference the document titled "Installation Procedure for the Utah-200 Breakout Panel and Cable Assembly."

Also reference the "BPS-2020 / Bypass Switcher" manual for the details of the audio pinouts.

Using the UTAH-200 Breakout Panel on the BPS-2020

This section provides details about the physical INPUT connections of the UTAH-200 breakout panel when used with the BPS-2020.

- The BPS-2020 supports eight inputs. Each audio input can have up to eight channels (four AES streams) of digital audio. If your system has only one audio board installed then it will support only four audio channels (two AES streams).
- In the referenced document, the label “Inputs 0-7” refers to the eight inputs for audio channels 1 and 2 (AES stream 1).
- In the referenced document, the label “Inputs 8-15” refers to the eight inputs for audio channels 3 and 4 (AES-2).
- If you have two audio boards installed, you will use a second breakout panel to connect the audio channels 5-8. The labels on the second breakout panel are as follows: The label “Inputs 0-7” refers to channels 5 and 6 (AES-3) and the label “Inputs 8-15” refers to channels 7 and 8 (AES-4).

This section provides details about the physical OUTPUT connections of the UTAH-200 breakout panel when used with the BPS-2020.

- The BPS-2020 supports a single output. Therefore most pins on the output connectors are not used.
- In the referenced document, the label “Outputs 0-7” refers to the outputs for channels 1 and 2 (AES-1) and channels 5 and 6 (AES-3).
- In the referenced document, the label “Outputs 8-15” refers to the outputs for channels 3 and 4 (AES-2) and channels 7 and 8 (AES-4).
- Output 0 of the “Outputs 0-7” connector is chan 1-2 (AES-1).
- Output 8 of the “Outputs 8-15” connector is chan 3-4 (AES-2).
- Output 1 of the “Outputs 0-7” connector is chan 5-6 (AES-3).
- Output 9 of the “Outputs 8-15” connector is chan 7-8 (AES-4).

The REF and MON connections are not used on either breakout panel. The Output connectors of the second breakout panel are also not used.



C

Appendix C Debug Port

Description

The P1 connector on the crosspoint card is a diagnostic port used for system upgrades, configuration and debugging. It is an RS-232 port and must be communicated to with a suitable terminal emulation program installed on a PC. Utah Scientific provides a program called TeraTerm as part of its standard documentation package.

Connector

To ease the connection, an adapter from DB9 to RJ-45 is provided (USI Part Number 140000-8, "UT-400"). Simply plug this onto a DB9 serial port on a PC, and then connect a standard CAT5 cable terminated with RJ45 connectors from it to the P1 connector on the crosspoint card.

Terminal Emulation Settings

The following settings should be made in order to communicate with the BPS-2020.

- Baud Rate_38400.
- Data Bits_8.
- Stop Bits_1.
- Parity_ None.
- Handshake_XON/XOFF.

Verifying Communication

The Diagnostic Port reports every switch that is made, and responds to commands entered into the terminal. The menu is a very simple command, response format, where the appropriate keystroke causes an action in the diagnostic software. An example is the switch function, wherein the user can simply press the 0 key and the system will execute the switch to input 0. Pressing the space bar causes the system to display its menu.

```
*****  
BPS-2020 8/16 System Monitor MENU - V2.00  
*****  
0-7 = Make Switches.  
G = Genlock Part Status.  
Q = Clean Quiet Module Status.  
S = System Level Status.  
W = Write Registers.  
R = CQ Register Dump.  
B = Toggle Bypass Relay.  
C = Configure video standard and reference input.
```

After the menu is shown, you simply press the letter of the function you want in order to invoke it.

The most useful customer functions are 'B' and 'C', to bypass the system or configure the reference standard. See the operations section (CH.2) for more information on these functions.



D

Firmware Update Procedure

Description

The firmware on the Video Crosspoint Card will provide the ability to field reprogram the DSP. Before you attempt to upgrade software in the card, consult with Utah Scientific Customer Service to ensure you are upgrading to the proper version for your application.

Procedure

Before attempting, ensure that you have connected to the card as described in Appendix C of this manual, and are able to access the menus using TeraTerm. Information regarding TeraTerm's installation and configuration can be found in the Utah Scientific System Installation Guide.

CAUTION - THIS UPGRADE WILL RENDER THE CARD INOPERABLE FOR 1 MINUTE. YOU MUST PHYSICALLY BYASS THE ROUTER OR WAIT FOR A SUITABLE TIME WINDOW TO PERFORM THE UPGRADE.

Follow the procedure below to program this board.

1. Using a CAT5 cable with the 140000-8 serial adapter (labeled UT400), connect to COM1 of your computer, then to P1 of the 121188-1 crosspoint card.

2. Open TeraTerm on your PC.
 - Set it up for COM1, 38400 baud, 8 data, 1 stop with no parity bits, and XON/XOFF handshake.
3. Press the reset button on the 121188-1. Press ENTER immediately after you see “© 2007 USI. S-Record Loader. Version 1.0” (It is important that ENTER is pressed *before* the “Application Started” prompt appears.)
4. In TeraTerm, select the option 'File' then 'send'. Select the file provided to you by USI customer service (a typical file name is “08215-01 SW V2_06.S”).

Press OK to continue

- A successful download will show a window indicating that data is downloading for about 20 seconds, following by a version banner being printed indicating the version that was just downloaded.
- An unsuccessful download will not show the correct version. In this case, repeat steps 3 and 4.

Index

A

AES Audio 3-2
Analog Audio
 specification 3-1
audio board B-2
Audio Connections 1-5, 2-7, A-3

B

Baud Rate 2-7
BPS-2020
 video DA card 1-14
BPS-NET ports 2-6
Break Out Addendum B-1
Breakout Options 2-7
Breakout Panel B-2
Bypass Switcher
 specifications 1-8

C

card controls 1-11
Card Installation 1-8
CAT-5 cable 1-4
CAT5 cable D-1
clean quiet module 2-3, 2-4, C-2
COM and GPI1-8 pins 2-6
Control
 specifications 3-3
Control Connectors 2-6
Control Interconnections 1-4
Control Options 2-2
Control Panel Variations 1-2

D

Development Scope 1-8

E

Equipment List 1-1

F

Features 2-2
Firmware Update D-1
Format 2-7, A-1

I

Indications
 control panel 2-2

M

Multichannel 1-2
Multichannel Connections 1-5

O

Operational Description 1-8
operational overview 2-1

P

PANEL Port 2-6
PCB
 mounted controls and indicators 1-9
Power Requirement 3-1
Power Supplies 1-9, 2-2
 card installation 1-8
Protocol 2-7

R

Rear Panel Description 2-6
RJ-45 connector 1-4
RS-485 1-2

S

Serial Port 2-7, A-1
Specifications 3-1
System Installation 1-4
System Layout 1-2

T

tally
 RS-252/244 1-4
Tally Output 2-7, A-2
TeraTerm D-2
terminal block 2-6

U

Unpacking 1-1
UT-200 B-1

V

Veetronix 1-2
Vfade 2-4
Video
 specification 3-1
Video Connections 1-6