

UTAH-400 Data Rear View



Serial Data Connector Pinouts

Tributary Mode

1&2 = gnd, 3 = TX Common, 4 = TX-, 5 = TX+, 6 = RX Common, 7 = RX+, 8 = RX-

Serial Data Connector Pinouts

Controller Mode

1&2 = gnd, 3 = RX Common, 4 = RX-, 5 = RX+, 6 = TX Common, 7 = TX+, 8 = TX-

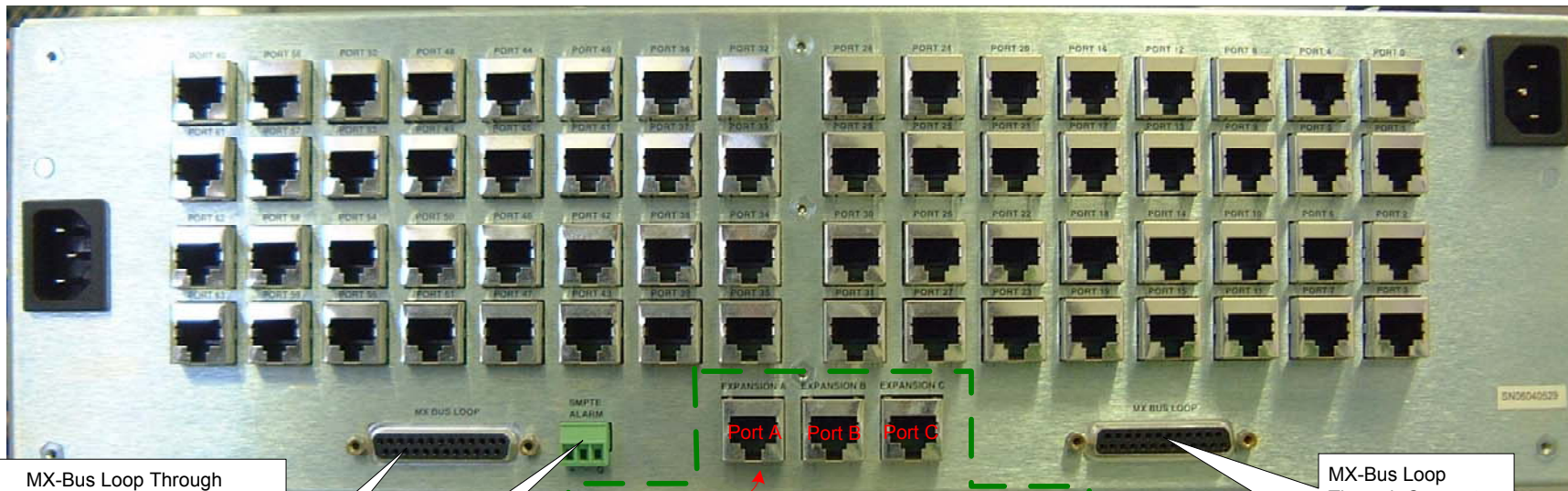

MX-Bus Loop Through
Connect to one of the two MX-bus connections on the SC-4 or another router frame. Both MX ports must be terminated, either on the SC-4 or at the router chassis. Maximum length of 300 feet. See block diagram below for a typical installation.

SMPTE Alarm
Relay closure indicating over temperature, power supply or fan failure

MX-Bus Loop Through Connector. See note on the left side of this page.

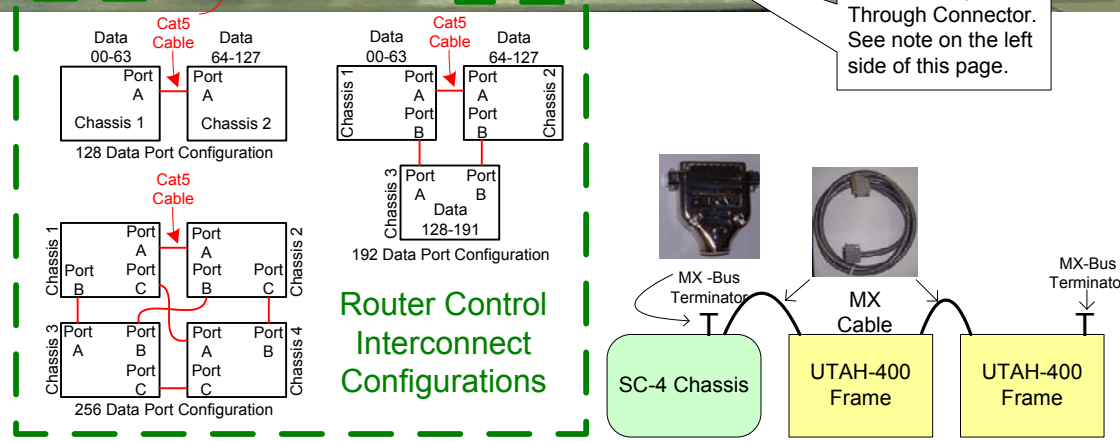

UTAH-400 Data Front View

